

Application Bulletin

Belimo PICCV Flow Verification & Commissioning

This document details the flow verification and commissioning procedures for PICCV (pressure independent characterized control valves). The flow verification techniques contained within this document are optional and at the discretion of the Mechanical Engineer/Designer. These procedures are not mandatory to ensure proper operation of PICCV valves. Pressure independent control valves are very different than a pressure dependent control valve. Pressure variations in the system will not affect flow through the valve. The ability to adjust and/or control the flow rate which passes through the PI valve is not possible via another mechanical device and additional mechanical devices should not be used. This makes the TAB/Commissioning process much different than with standard control valves. Pressure independent valves offer numerous maximum design flow values in each valve body size. It is important to note that most pressure independent valves will not travel a full 90 degrees of rotation when commanded to full design flow position. Design flow in a PICCV is adjusted through the maximum angle of ball travel. Therefore, if the valve's maximum flow setting is not at the end of the range, the valve will travel to a point less than 90 degrees. This is normal operation for pressure independent control valves.

Note to Mechanical Designer/Owner: It is essential that the mechanical contractor install three (3) independent pressure/temperature ports if the PICCV is not supplied with integrated ports. Please refer to Figure A contained in this document for P/T port locations. External P/T ports allow for true independent verification of proper PICCV operation. Additionally, the external P/T ports allow for future comprehensive troubleshooting and diagnosis once the system has been in operation for an extended time period.

For proper and accurate flow verification of the PICCV, it is essential that the mechanical contractor install two (2) separate independent pressure/temperature ports (P/Ts) if the PICCV valve body is supplied with integrated ports. (See Figure A - the integrated P/T port labeled 3b performs the same function as P/T port 3a).

I. P/T port #1 and P/T port #2 are used for measuring pressure differential across the coil (used to measure water pressure drop to equate to flow or to measure water temperature delta T through the coil).

II. P/T port #2 and P/T port #3a (or #3b if integrated into valve body) are used to measure pressure drop across the PICCV (must be between 5-50 psi pressure across valve body). Pressure Independent valve body

must have required differential pressure within this range WITH VALVE ASSEMBLY COMMANDED TO DESIGN FLOW. Valve shall be commanded to design flow position via EMS signal. Do not manually open the valve with override handle. This pressure difference across the PICCV is necessary to ensure the valve is working pressure independently.

Pre Flow Verification System Checklist

In order to ensure a properly functioning hydronic system utilizing Pressure Independent Characterizing Control Valves, the mechanical contractor and/or T&B professional must verify that the following items have been confirmed before beginning flow verification.

Each flow verification / commissioning procedure presented in this document begins with a reference to the checklist contained below. This serves as a constant reminder to the flow verification professional that these parameters must be met so that proper flow results can be measured / obtained.

*Items to check before beginning flow verification procedure:

- Verify that System is purged of air and filled to proper pressure.
- Verify that each PICCV valve has at least 5 psi but less than 50 psi dP across the valve (fig. A) by following one of the following two measurement options:
 - Reading taken across P/T ports 2 & 3a
 - Reading taken across P/T ports 2 & 3b (3b only available on PICCV models containing P/T ports) PT port versions of PICCV will no longer be available after 1st quarter 2009.
- Verify Proper pump operation per manufacturers specifications.
- Verify proper supply water temperature is available and is at design temperature.
- Proper Air filter maintenance has been completed.
- Fan belts are in proper working order.
- Heat transfer devices (coils) are clean.
- Strainers are clean.
- All manual shutoff valves are open.

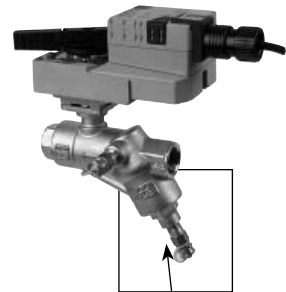

3B
P/T port versions of PICCV will no longer be available after March 2009.

Figure A

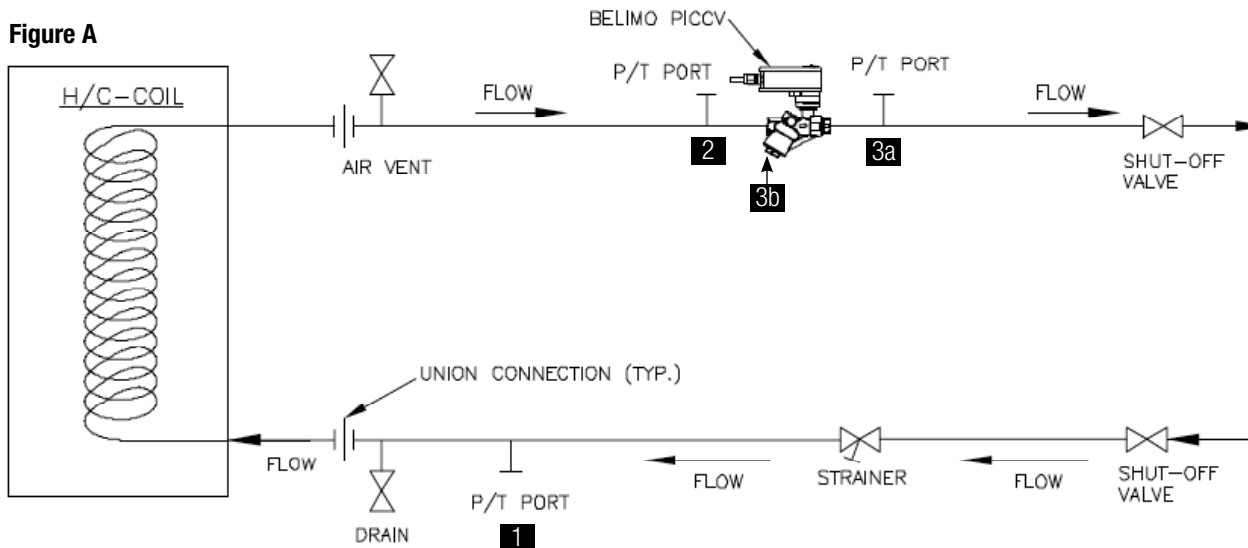

- All bypass valves are closed.
- No automatic or manual balancing valves exist (or if they do, they must be set fully open and locked so as not to interfere with the pressure independency of the PICCV).

Below are the accepted procedures for verifying/commissioning pressure independent control valves.

Procedure #1 (System Verification) – Total System Flow Method

Verification for PICCV Cooling Valves/Heating Valves

1. Verify that System is in proper working order. *See Items to check before beginning flow verification procedure contained at the beginning of this document.
2. Command open all PICCVs in a given system via the building automation system if the total connected load matches the pump capacity and system diversity = 100%. Systems with less than 100% diversity need to have a % of valves closed to match pump capacity.
3. Ensure that pumps are commanded to 100% speed (or VFD control loop has high enough dP setpoint to satisfy connected load).
4. Verify total system flow is at system design flow rate via accurate method:
 - Calibrated Circuit Setter on main lines
 - Orifice
 - Venturi
 - Ultrasonic Flowmeter
5. Decrease the pump speed (or decrease dP setpoint if under control) until a measureable flow decrease occurs.
6. Increase pump speed (or increase dP setpoint if under control) slowly until design flow is reestablished. Make note of this final measured dP. This will be the correct system dP operating setpoint.

NOTE: If total flow does not match design flow then troubleshooting must be done to determine cause. This may involve verifying flows at the terminal level.

Procedure #2 (Terminal Level Verification) – Air DeltaT Method

Verification for PICCV Cooling Valves/Heating Valves

1. Verify that System is in proper working order. *See Items to check before beginning flow verification procedure contained at the beginning of this document.
2. Ensure that water is at design temperature.
3. Ensure that terminal airflow is at design airflow rate (cfm).
4. Command open pressure independent characterized control valve to maximum design flow position
5. Reference approved engineering document containing design air delta T for heating/cooling coil associated with corresponding pressure independent characterized control valve.
6. Measure coil inlet air temperature and coil discharge air temperature.
7. Difference between coil inlet air reading and coil discharge air reading should equal or exceed design air delta T.

Procedure #3 (Terminal Level Verification) – Water DeltaT Method

Verification for PICCV Cooling Valves/Heating Valves

1. Verify that System is in proper working order. *See Items to check before beginning flow verification procedure contained at the beginning of this document.
2. Ensure that water is at design temperature.
3. Ensure that terminal airflow is at design flow rate (cfm).
4. Command open pressure independent characterized control valve to maximum design flow position.
5. Reference approved engineering document containing design water deltaT for heating/cooling coil associated with corresponding pressure independent characterized control valve.
6. Measure water temperature differential of coil by using P/T ports #1 and #2 as referenced in Figure A.
7. Measured temperature differential should be equal to designed water temperature differential.

Procedure #4 (Terminal Level Verification) – Coil dP (DeltaP) Method

Verification for PICCV Cooling Valves and PICCV Heating Valves

1. Verify that System is in proper working order. *See Items to check before beginning flow verification procedure contained at the beginning of this document.
2. Command open pressure independent characterized control valve to maximum design flow position.
3. Reference approved engineering document containing design coil water pressure drop (usually expressed in ft. of H2O) for design flow. This value will be for the heating/cooling coil associated with corresponding pressure independent characterized control valve.
4. Measure coil dP by using P/T ports #1 & #2 as referenced in Fig. A.
5. Formula to calculate flow is:

$$\text{Actual GPM} = \sqrt{(\text{Measured Coil dP} / \text{Design Coil dP})} \times \text{Design GPM}$$

Note: Coil dP and Design dP expressed in feet of H2O.

Procedure #5 (Terminal Level Verification) – Integrated PICCV PT Port Method

Verification for PICCV Cooling Valves and PICCV Heating Valves

1. Verify that System is in proper working order. *See items to check before beginning flow verification procedure contained at the beginning of this document.
2. Command open pressure independent characterized control valve to maximum design flow position.
3. Measure pressure dP across P/T ports #3B and 3C as referenced in Fig. B on page 3.
4. Compare the pressure reading obtained against the dP charts provided by Belimo within the following document: 2008 Technical Documentation – Pressure Independent Characterized Control Valves (PICCV). This document is available on the Belimo

website at www.belimo.us. This document can be found under the documentation tab on the website.

5. The dP readings for the valve being verified can be found in section labeled Field Adjustable Flow Ranges and P/T Port Pressure Flow Data.
6. Please note: the dP reading obtained using integral P/T ports specifically show the dP across the ball portion of the PICCV and not the entire valve body. The integral P/T ports cannot be used to verify that the proper differential pressure is present across the entire valve body (proper dP must be between 5-50 psi pressure across valve body).

P/T port versions of PICCV will no longer be available after March 2009.

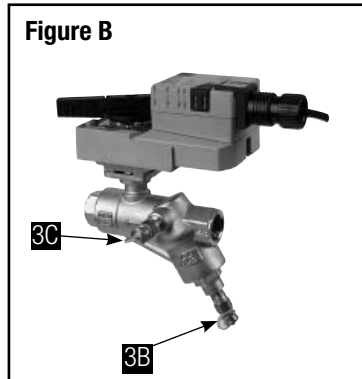

Field adjustment of maximum flow and /or flow accuracy. (This function is not a requirement. This procedure is purely optional and is not a mandatory procedure for proper operation of PICCV valves.)

Flow Accuracy of the PICCV valve body is +/-10%. However, actuator hysteresis and installation can have an effect on measured accuracy of the PICCV assembly (actuator/valve) in the field. The accuracy of the PICCV assembly can be improved in the application.

The maximum flow setting and/or flow accuracy can be adjusted in the field using the Belimo PC Tool. Please contact your local Belimo representative to obtain/purchase this tool or arrange to have a Belimo representative visit the project site to make adjustments.

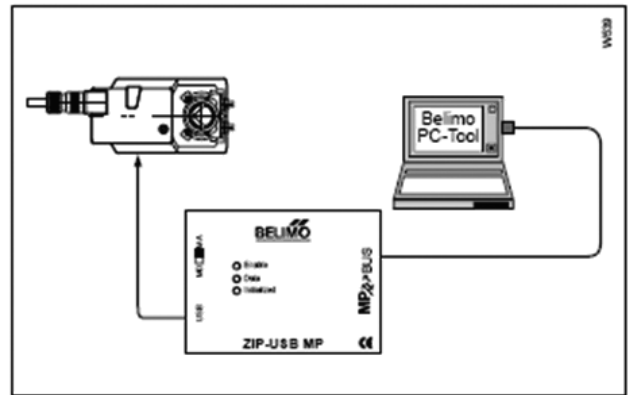

Note: The new PICCV actuator adjustment tool for flow verification and commissioning professionals will become available second quarter of 2009. Check with sales manager and/or Belimo technical support as to availability.

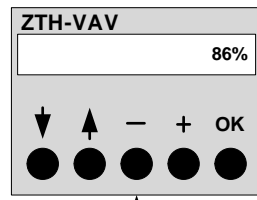

For additional information pertaining to the flow verification and commissioning industry, please visit the website of these organizations that promote the certification and continuing education of industry professionals in the Test and Balance discipline.

NEBB - National Environmental Balancing Bureau, <http://www.nebb.org/>

TABB - Testing adjusting Balancing Bureau, <http://www.tabbcertified.org/>

Belimo worldwide: www.belimo.com

BELIMO Americas

USA Locations, 43 Old Ridgebury Road, Danbury, CT 06810
Tel. 800-543-9038, Fax 800-228-8283, marketing@us.belimo.com

1675 East Prater Way, Suite 101, Sparks, NV 89434
Tel. 800 987-9042, Fax 800-987-8875, marketing@us.belimo.com

Canada Locations, 14/16 – 5716 Coopers Avenue, Mississauga, Ontario L4Z 2E8
Tel. 866-805-7089, Fax 905-712-3124, marketing@us.belimo.com

Latin America Customer Service, Tel. 203-791-8396, Fax 203-791-9139, marketing@us.belimo.com

